

## LOW POWER DUAL BIPOLAR OPERATIONAL AMPLIFIERS

- GOOD CONSUMPTION/SPEED RATIO : ONLY 200 $\mu$ A/Amp FOR 2.1MHz, 2V/ $\mu$ s
- SINGLE (OR DUAL) SUPPLY OPERATION FROM +4V TO +44V ( $\pm$ 2V TO  $\pm$ 22V)
- WIDE INPUT COMMON MODE VOLTAGE RANGE INCLUDING  $V_{CC}^-$
- LOW LEVEL OUTPUT VOLTAGE CLOSE TO  $V_{CC}^-$  : 100mV TYPICAL
- PIN TO PIN COMPATIBLE WITH STANDARD DUAL OP AMPS

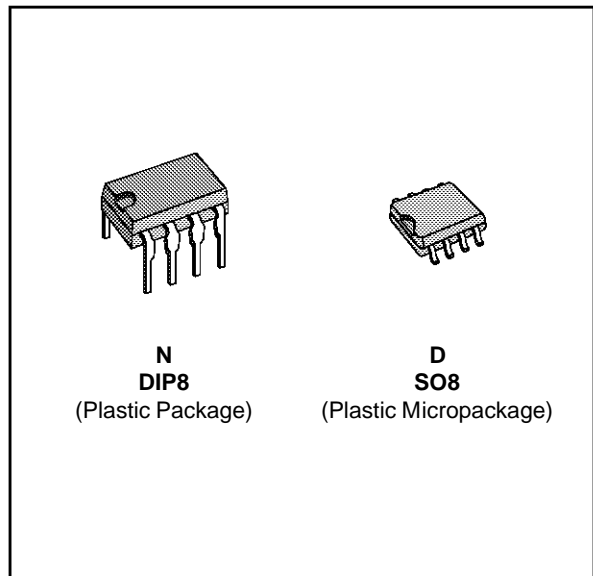

### DESCRIPTION

The MC33172 series are dual bipolar operational amplifiers offering both low consumption (200 $\mu$ A/Amp) and good speed (2.1MHz, 2V/ $\mu$ s). Moreover the Input Common Mode Range extends down to the lower supply rail, allowing single supply operation from +4V to +44V.

### ORDER CODES

Part Number	Temperature Range	Package	
		N	D
MC33172	-40°C, +105°C	•	•
MC35172	-55°C, +125°C	•	•
<b>Example:</b> MC33172N			

33172-01.TBL

### PIN CONNECTIONS (top view)

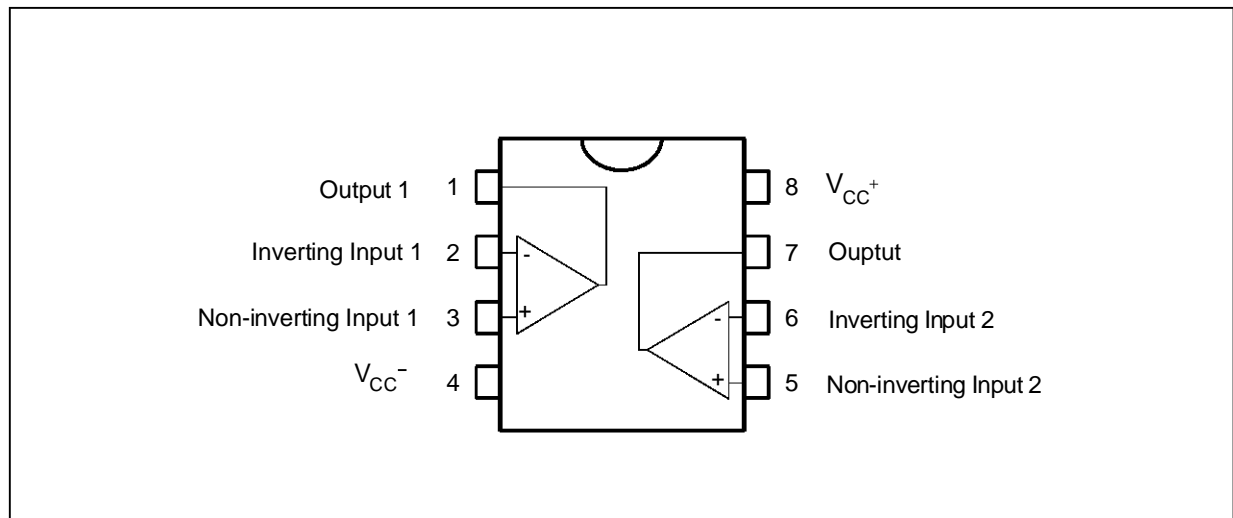

33172-01.EPS

**SCHEMATIC DIAGRAM** (for 1/2 MC33172)

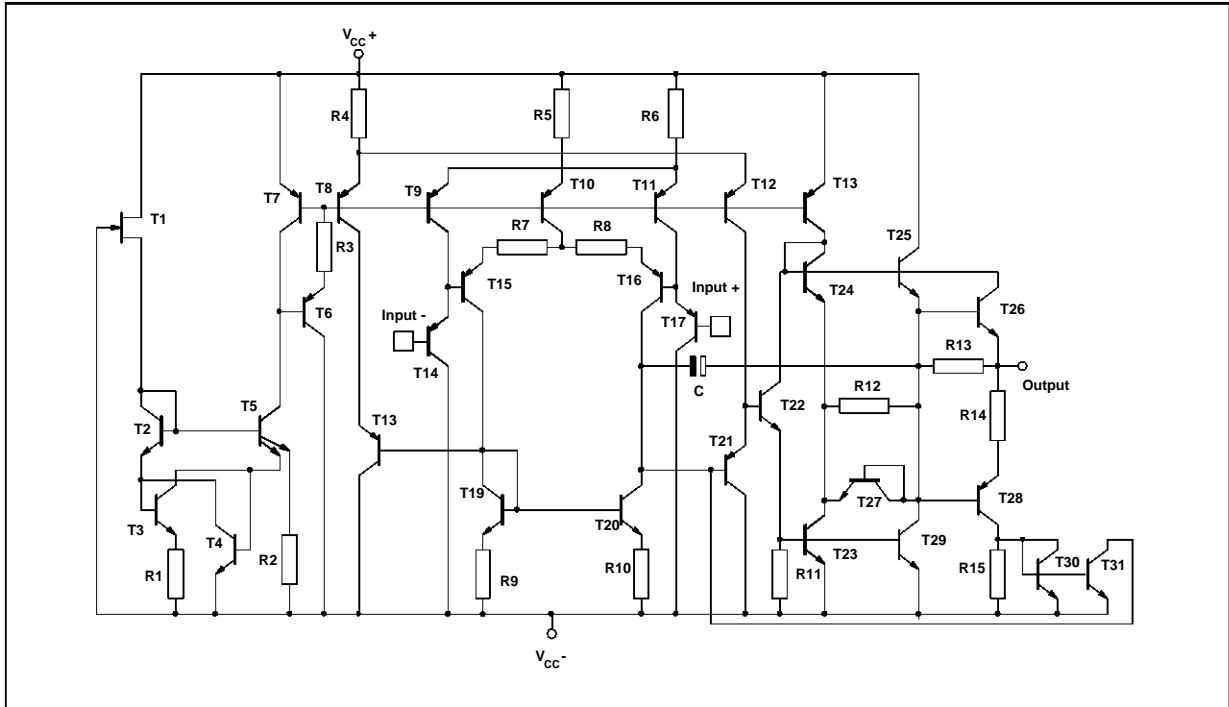

33172-02.EPS

**ABSOLUTE MAXIMUM RATINGS**

Symbol	Parameter	Value	Unit
$V_{CC}$	Supply Voltage	$\pm 22$	V
$V_{id}$	Differential Input Voltage	(Note 1)	V
$V_i$	Input Voltage	(Note 1)	V
	Output Short Circuit Duration	Indefinite	s
$T_{oper}$	Operating Temperature Range	MC33172 MC35172	$^{\circ}C$
$T_j$	Junction Temperature	150	$^{\circ}C$
$T_{stg}$	Storage Temperature	-65 to 150	$^{\circ}C$

**Note 1:** Either or both input voltages must not exceed the magnitude of  $V_{CC}$ .

33172-02.TBL

**OPERATING CONDITIONS**

Symbol	Parameter	Value	Unit
$V_{CC}$	Supply Voltage Range	$\pm 2$ to $\pm 22$	V

33172-03.TBL

**ELECTRICAL CHARACTERISTICS** $V_{CC}^+ = +15V$ ,  $V_{CC}^- = -15V$ ,  $R_L$  connected to Ground,  $T_{amb} = 25^\circ C$  (unless otherwise specified)

Symbol	Parameter	Min.	Typ.	Max.	Unit
$V_{io}$	Input Offset Voltage $V_{CC}^+ = +15V$ , $V_{CC}^- = -15V$ , $V_{ic} = 0V$ $V_{CC}^+ = 5V$ , $V_{CC}^- = 0V$ , $V_{ic} = 0V$ , $V_o = 1.4V$ $V_{CC}^+ = +15V$ , $V_{CC}^- = -15V$ , $V_{ic} = 0V$ , $T_{min.} \leq T_{amb} \leq T_{max.}$		1 1	4.5 5 6.5	mV
$DV_{io}$	Input Offset Voltage Drift		10		$\mu V/^\circ C$
$I_{io}$	Input Offset Current ( $V_{ic} = 0V$ ) $T_{min.} \leq T_{amb} \leq T_{max.}$		5	20 40	nA
$I_{ib}$	Input Bias Current ( $V_{ic} = 0V$ ) $T_{min.} \leq T_{amb} \leq T_{max.}$		20	100 200	nA
$A_{vd}$	Large Signal Voltage Gain ( $R_L = 10k\Omega$ , $V_o = \pm 10V$ ) $T_{min.} \leq T_{amb} \leq T_{max.}$	50 25	100		V/mV
$V_{OH}$	High Level Output Voltage $V_{CC}^+ = 5V$ , $V_{CC}^- = 0V$ , $R_L = 10k\Omega$ $V_{CC}^+ = +15V$ , $V_{CC}^- = -15V$ , $R_L = 10k\Omega$ $V_{CC}^+ = +15V$ , $V_{CC}^- = -15V$ , $R_L = 10k\Omega$ , $T_{min.} \leq T_{amb} \leq T_{max.}$	3.5 13.6 13.3	4.2 14.2		V
$V_{OL}$	Low Level Output Voltage $V_{CC}^+ = 5V$ , $V_{CC}^- = 0V$ , $R_L = 10k\Omega$ $V_{CC}^+ = +15V$ , $V_{CC}^- = -15V$ , $R_L = 10k\Omega$ $V_{CC}^+ = +15V$ , $V_{CC}^- = -15V$ , $R_L = 10k\Omega$ , $T_{min.} \leq T_{amb} \leq T_{max.}$		0.1 -14	0.15 -13.6 -13.3	V
$I_{sc}$	Output Short Circuit Current ( $V_{id} = \pm 1V$ , $V_o = 0V$ ) Source Sink	3 15	6 27		mA
$V_{icm}$	Input Common Mode Voltage Range $T_{min.} \leq T_{amb} \leq T_{max.}$				V
CMR	Common Mode Rejection Ratio ( $V_i = V_{icm \text{ min.}}$ )	80	100		dB
SVR	Supply Voltage Rejection Ratio ( $V_{CC} = \pm 5$ to $\pm 15V$ )	80	100		dB
$I_{cc}$	Supply Current (per amplifier) $V_{CC}^+ = 5V$ , $V_{CC}^- = 0V$ , no load $V_{CC}^+ = +15V$ , $V_{CC}^- = -15V$ , no load $V_{CC}^+ = +15V$ , $V_{CC}^- = -15V$ , no load, $T_{min.} \leq T_{amb} \leq T_{max.}$		200 220	250 250 300	$\mu A$
SR	Slew Rate ( $V_i = \pm 10V$ , $R_L = 10k\Omega$ , $C_L = 100pF$ )	1.6	2		V/ $\mu s$
GBP	Gain Bandwidth Product ( $R_L = 10k\Omega$ , $C_L = 100pF$ , $f = 100kHz$ )	1.4	2.1		MHz
$\phi_m$	Phase Margin ( $R_L = 10k\Omega$ , $C_L = 100pF$ )		45		Degrees
$e_n$	Equivalent Input Noise Voltage ( $f = 1kHz$ )		29		$\frac{nV}{\sqrt{Hz}}$
THD	Total Harmonic Distortion		0.05		%
$V_{O1}/V_{O2}$	Channel Separation		120		dB

33172-04-TBL

**PACKAGE MECHANICAL DATA**  
8 PINS - PLASTIC DIP

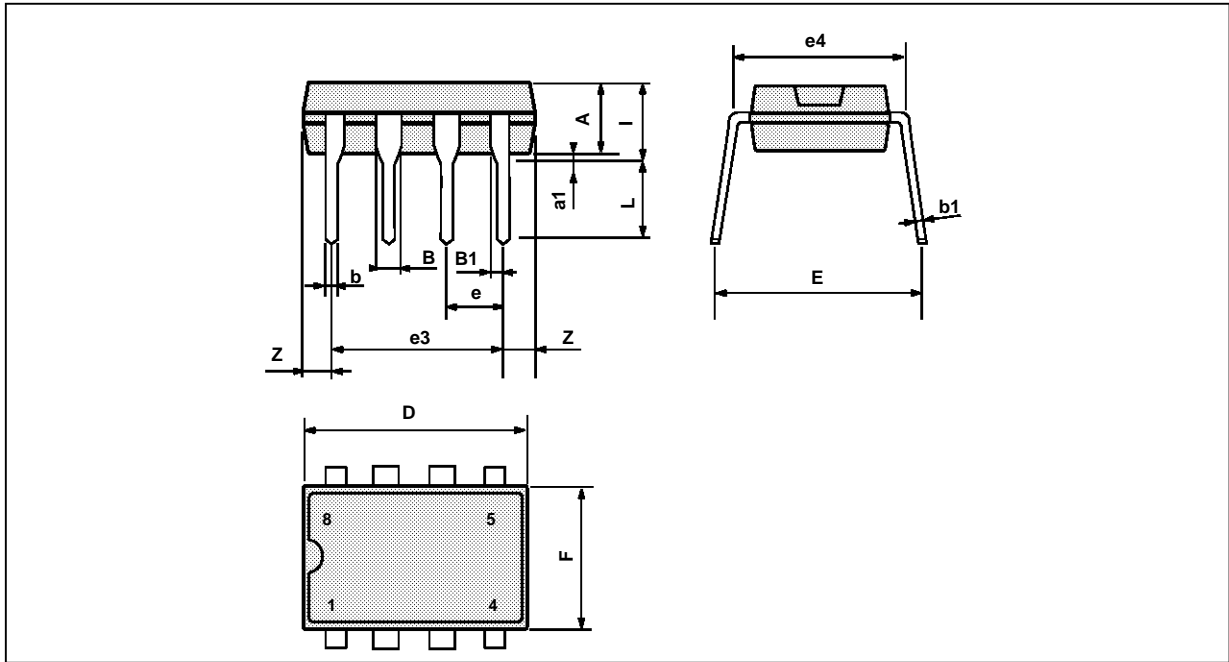

PM-DIP8.EPS

Dimensions	Millimeters			Inches		
	Min.	Typ.	Max.	Min.	Typ.	Max.
A		3.32			0.131	
a1	0.51			0.020		
B	1.15		1.65	0.045		0.065
b	0.356		0.55	0.014		0.022
b1	0.204		0.304	0.008		0.012
D			10.92			0.430
E	7.95		9.75	0.313		0.384
e		2.54			0.100	
e3		7.62			0.300	
e4		7.62			0.300	
F			6.6			0.260
i			5.08			0.200
L	3.18		3.81	0.125		0.150
Z			1.52			0.060

DIP8.TBL

**PACKAGE MECHANICAL DATA**  
8 PINS - PLASTIC MICROPACKAGE (SO)

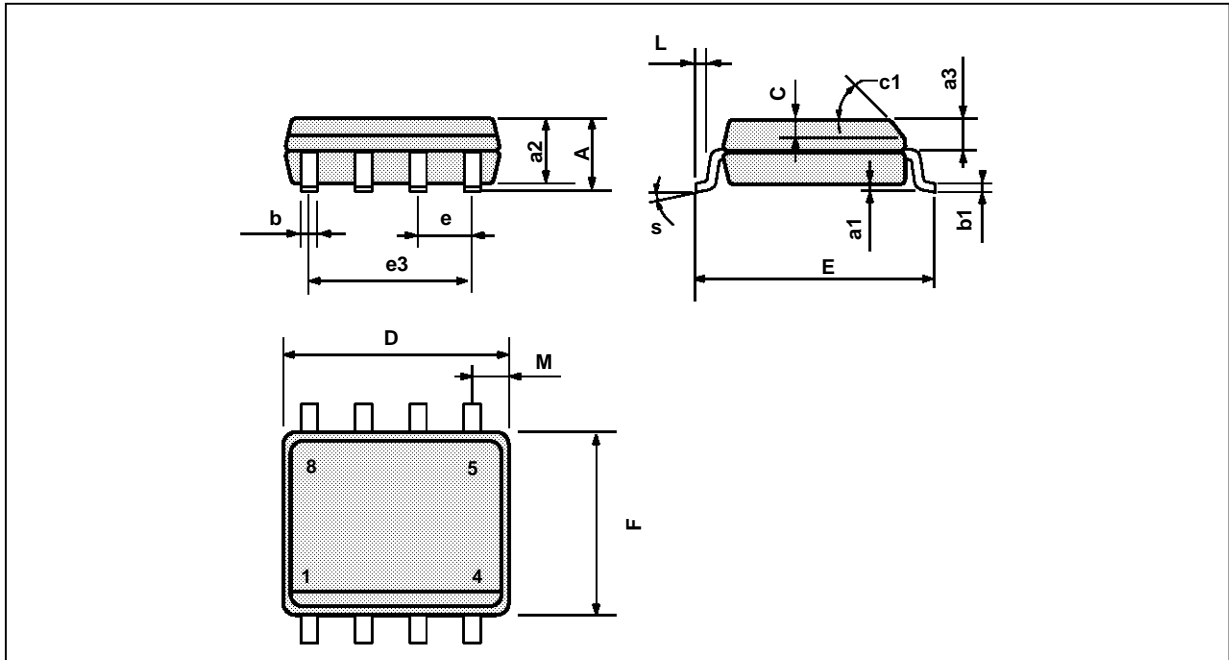

PM-S08.EPS

Dimensions	Millimeters			Inches		
	Min.	Typ.	Max.	Min.	Typ.	Max.
A			1.75			0.069
a1	0.1		0.25	0.004		0.010
a2			1.65			0.065
a3	0.65		0.85	0.026		0.033
b	0.35		0.48	0.014		0.019
b1	0.19		0.25	0.007		0.010
C	0.25		0.5	0.010		0.020
c1	45° (typ.)					
D	4.8		5.0	0.189		0.197
E	5.8		6.2	0.228		0.244
e		1.27			0.050	
e3		3.81			0.150	
F	3.8		4.0	0.150		0.157
L	0.4		1.27	0.016		0.050
M			0.6			0.024
S	8° (max.)					

S08.TBL

Information furnished is believed to be accurate and reliable. However, SGS-THOMSON Microelectronics assumes no responsibility for the consequences of use of such information nor for any infringement of patents or other rights of third parties which may result from its use. No licence is granted by implication or otherwise under any patent or patent rights of SGS-THOMSON Microelectronics. Specifications mentioned in this publication are subject to change without notice. This publication supersedes and replaces all information previously supplied. SGS-THOMSON Microelectronics products are not authorized for use as critical components in life support devices or systems without express written approval of SGS-THOMSON Microelectronics.

© 1995 SGS-THOMSON Microelectronics - All Rights Reserved

SGS-THOMSON Microelectronics GROUP OF COMPANIES  
Australia - Brazil - France - Germany - Hong Kong - Italy - Japan - Korea - Malaysia - Malta - Morocco - The Netherlands  
Singapore - Spain - Sweden - Switzerland - Taiwan - Thailand - United Kingdom - U.S.A.

ORDER CODE :